

# COMPONENTS

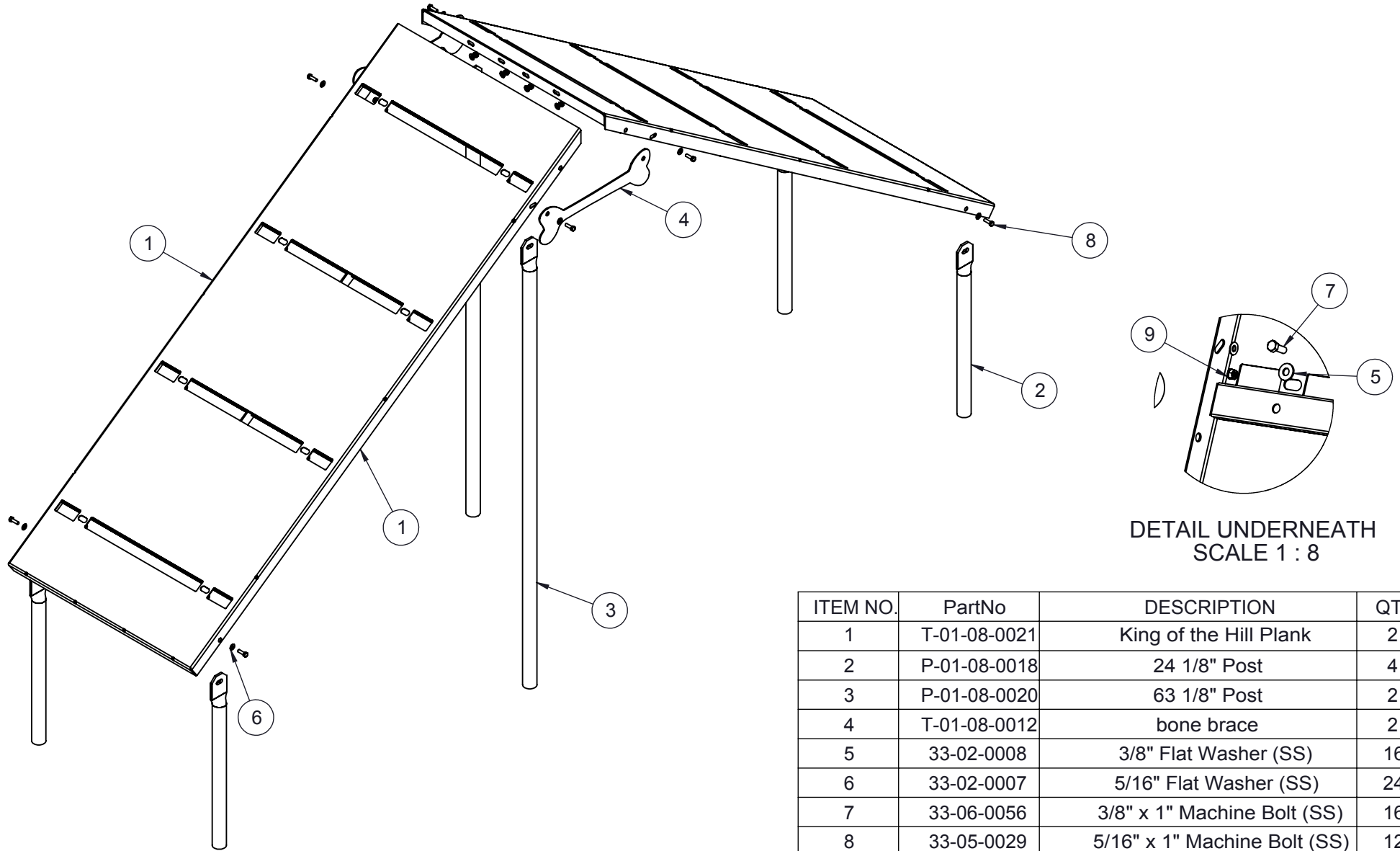

DETAIL UNDERNEATH  
SCALE 1 : 8

ITEM NO.	PartNo	DESCRIPTION	QTY
1	T-01-08-0021	King of the Hill Plank	2
2	P-01-08-0018	24 1/8" Post	4
3	P-01-08-0020	63 1/8" Post	2
4	T-01-08-0012	bone brace	2
5	33-02-0008	3/8" Flat Washer (SS)	16
6	33-02-0007	5/16" Flat Washer (SS)	24
7	33-06-0056	3/8" x 1" Machine Bolt (SS)	16
8	33-05-0029	5/16" x 1" Machine Bolt (SS)	12
9	33-03-0012	5/16" Kep Nut (SS)	12
10	T-01-08-0022	bark park step strip	8

# STEP 1

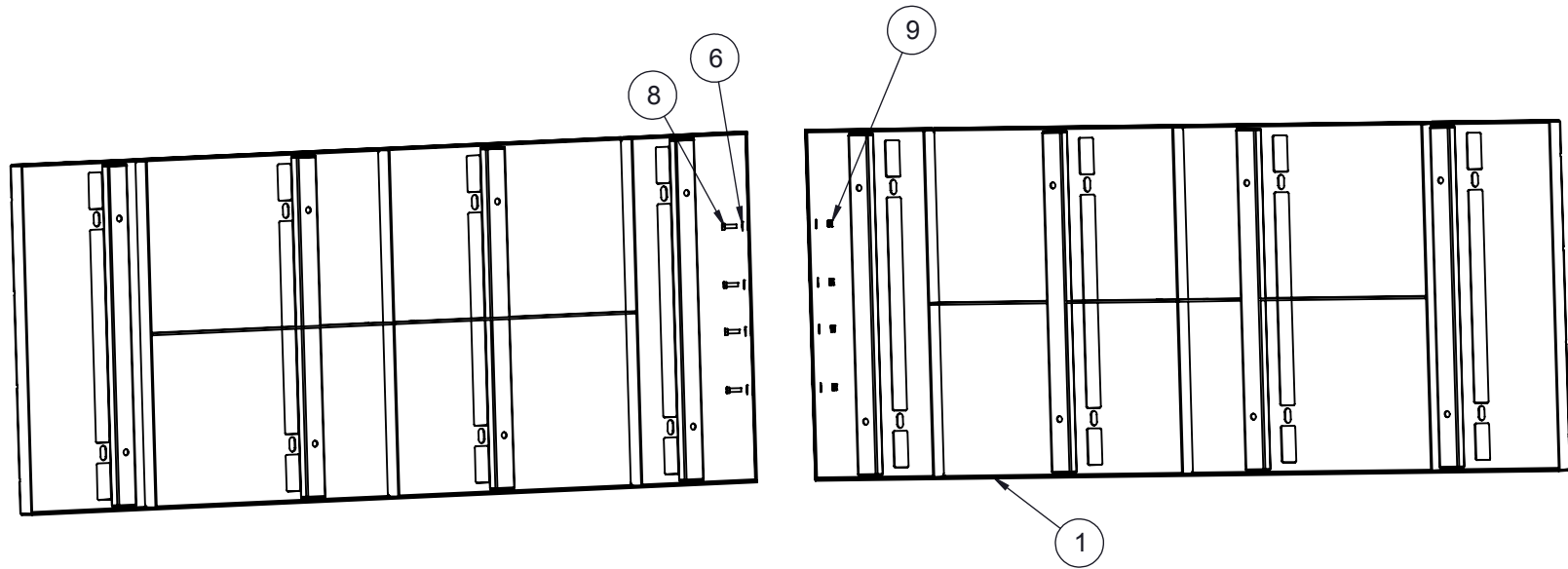

Bolt King of the Hill Planks  
together using specified  
hardware. (This is done best  
laying on its side.)

## STEP 2

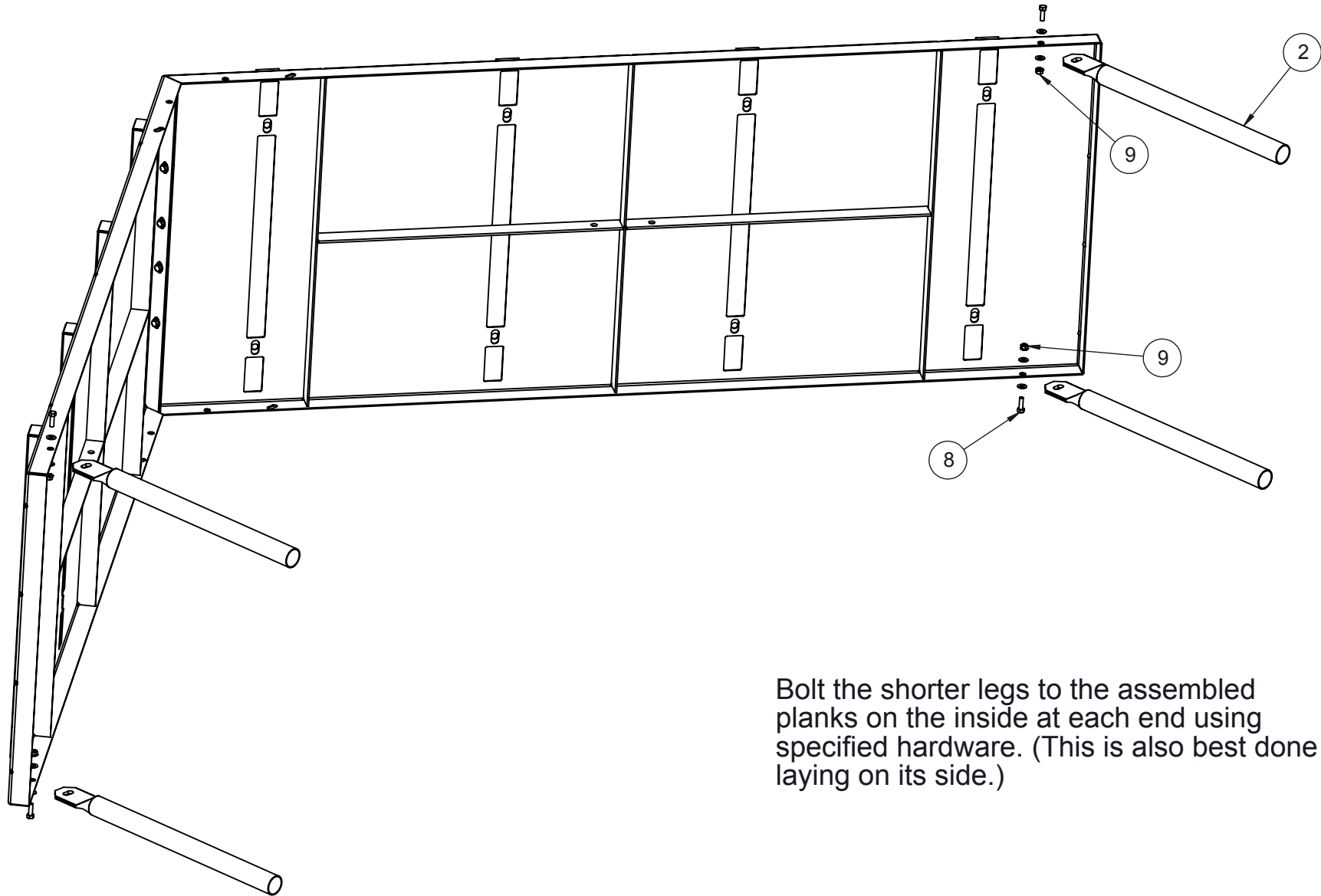

Bolt the shorter legs to the assembled planks on the inside at each end using specified hardware. (This is also best done laying on its side.)

## STEP 3

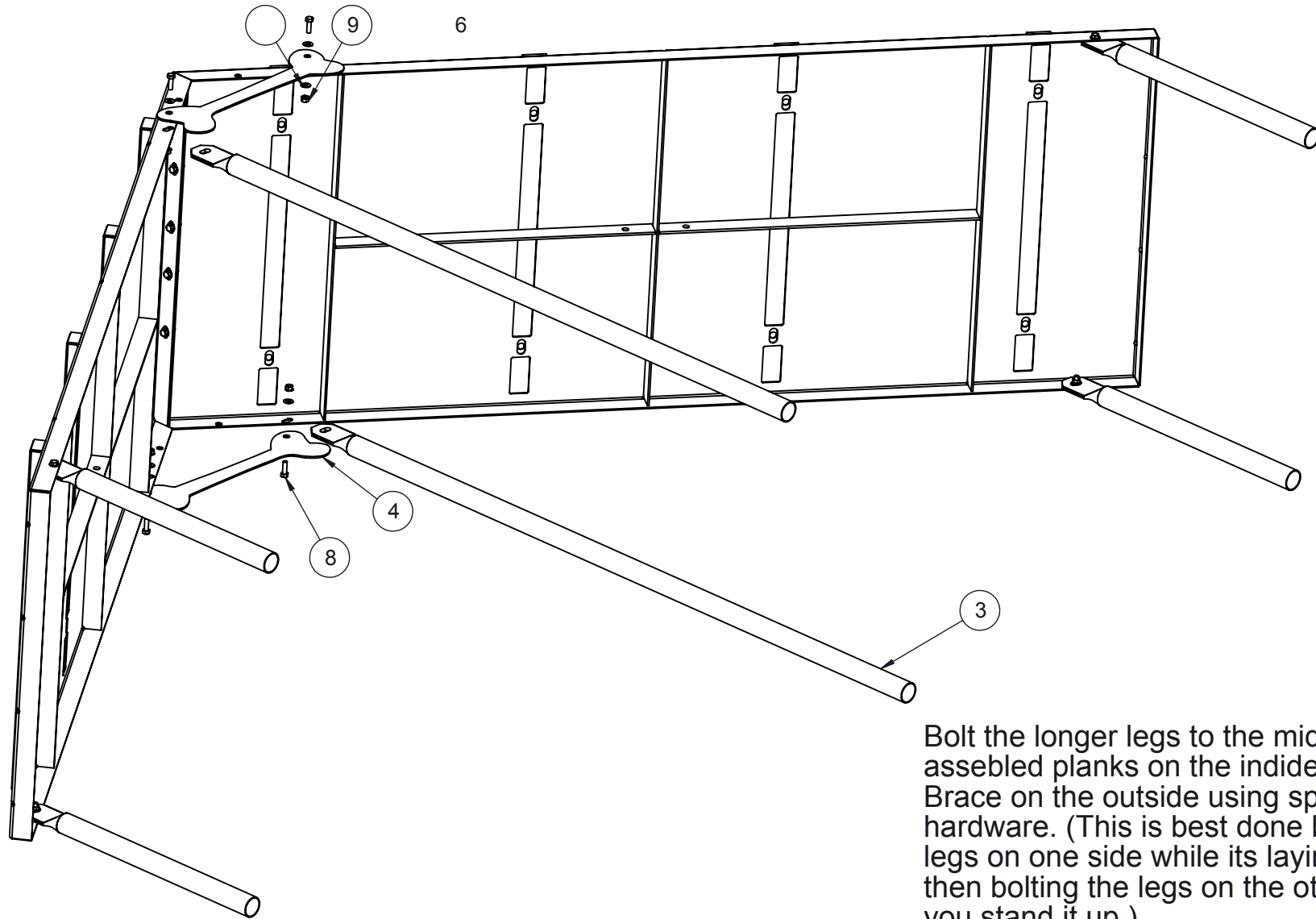

Bolt the longer legs to the middle of the assembled planks on the inside and the Bone Brace on the outside using specified hardware. (This is best done by bolting the legs on one side while its laying down and then bolting the legs on the other side after you stand it up.)

## STEP 4

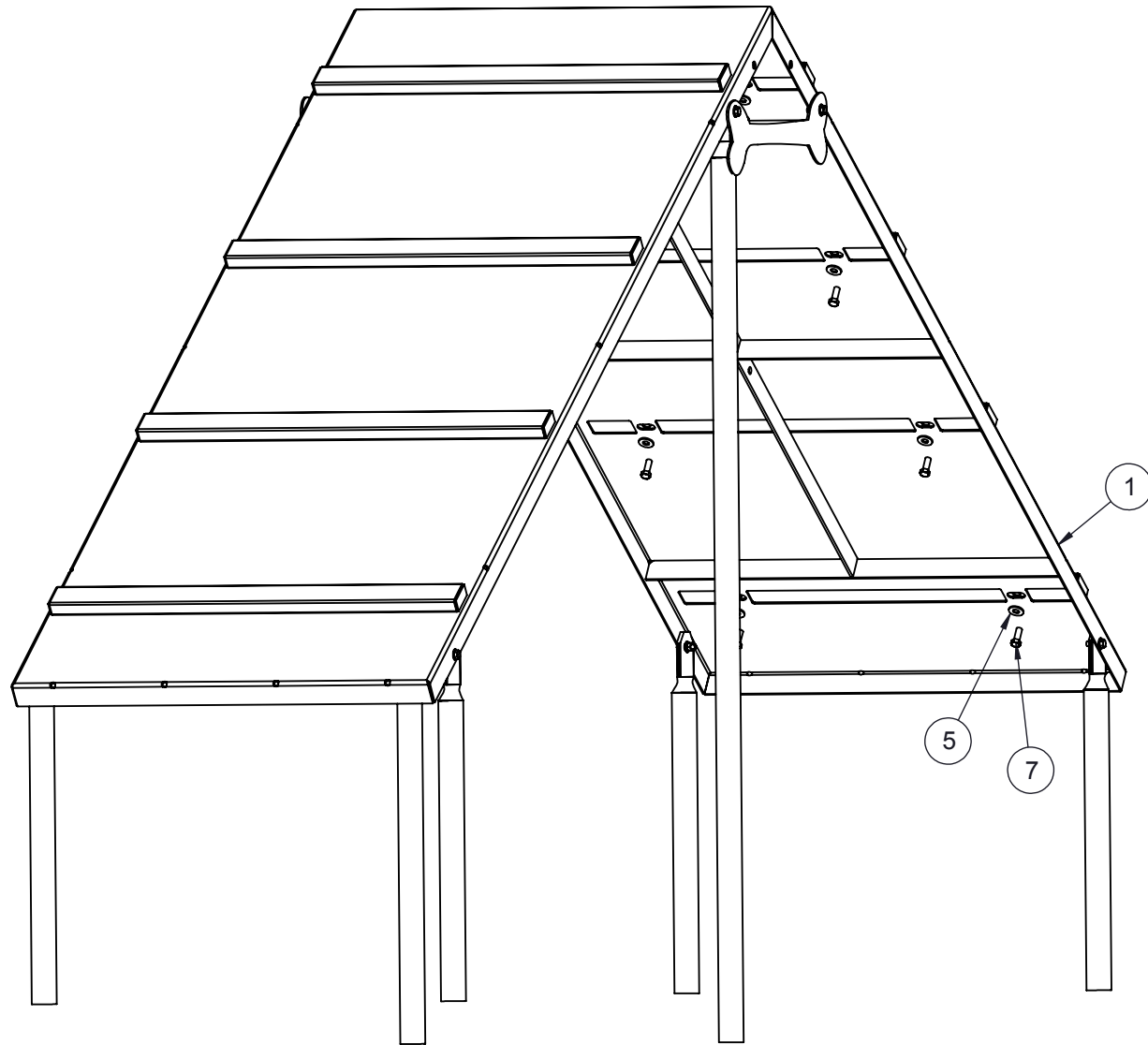

Attach the Step Strips  
using specified  
hardware.

# FOOTINGS

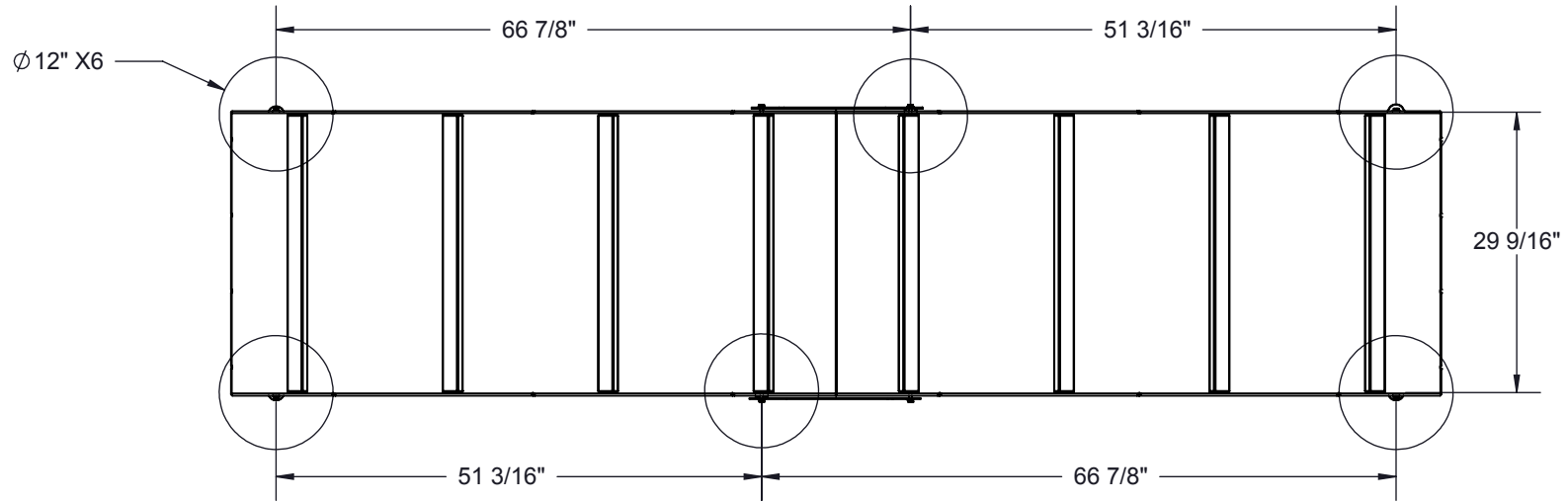

Estimated Required Concrete:  
26 - 50 lb. bags of concrete mix

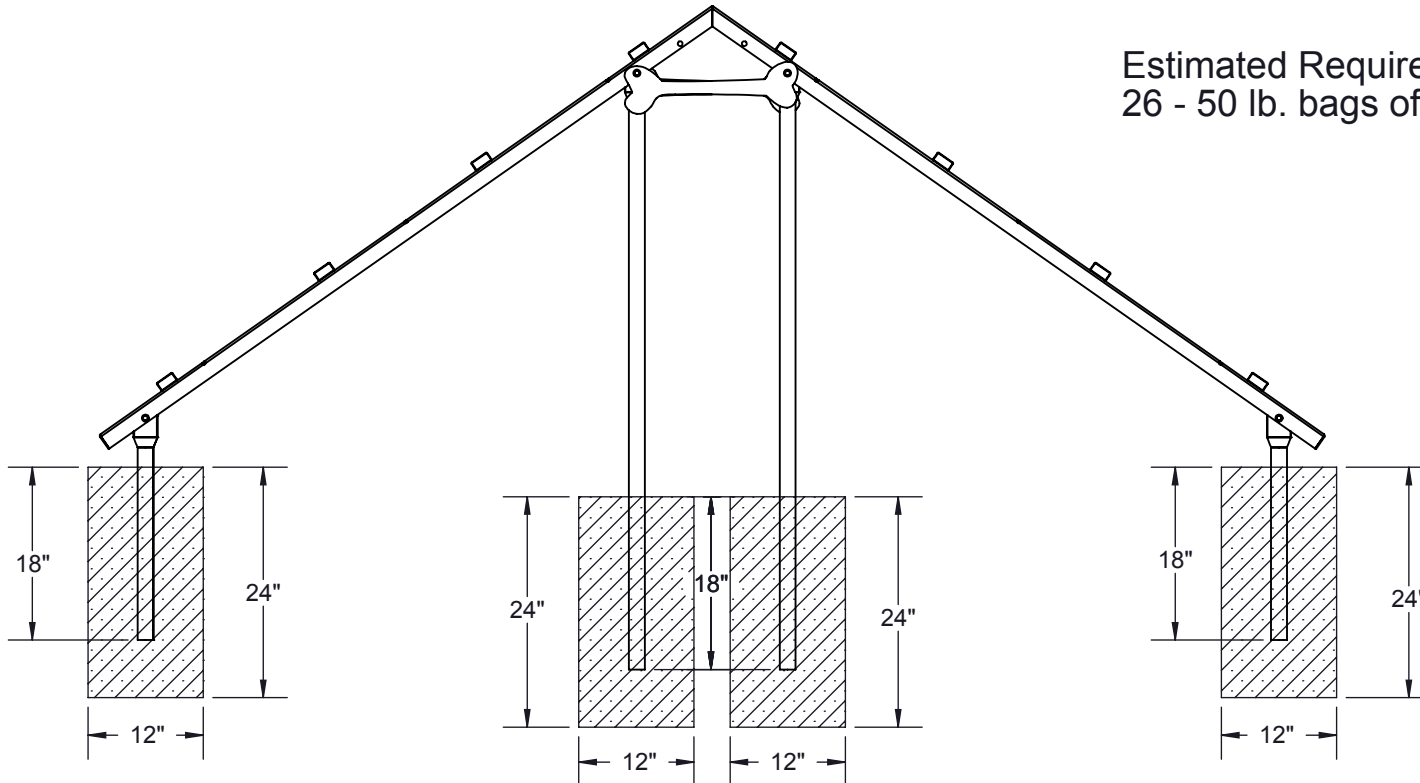

# OVERALL DIMENSIONS

